

QPA... Series Indoor Air Quality Room Sensors

Product Description

The QPA... Series Indoor Air Quality Room Sensors are especially suited for applications where precise, stable sensing of carbon dioxide (CO₂), temperature, or relative humidity is required. Some models sense volatile organic compounds (VOCs).

Product Numbers

Product Number	Description
QPA1000	VOC sensing only
QPA2000	CO ₂ sensing only
QPA2002	CO ₂ and VOC sensing only
QPA2002D	CO ₂ and VOC sensing with display
QPA2060	CO ₂ and temperature sensing (active) only
QPA2060D	CO ₂ and temperature (active) sensing with display
QPA2062	CO ₂ , temperature (active) and rh sensing only
QPA2062D	CO ₂ , temperature (active) and rh sensing with display
QPA2080	CO ₂ and temperature (passive) (depending on connected sensing element *)
QPA2080D	CO ₂ and temperature (passive) (depending on connected sensing element *) with display

NOTE: QPA1000, QPA2000, QPA2002, and QPA2060 are available as no-logo variants. To order, add an "N" suffix (for example: QPA1000N).

* LG-Ni1000, Pt1000, Pt100, or NTC 10K ohm.

Additional Reference Documents

Technical Instructions CE1N1961
 Technical Specification Sheet 149-910

Expected Installation Time

30 minutes

Required Tools

- Phillips screwdrivers, sizes 1 and 2
- Small and medium flat-blade screwdriver
- Wire cutters/strippers
- Tape measure
- Medium-duty electric drill
- Drill bit for wall anchor hole
- Marker or pencil
- Two No. 10 screws and wall anchors

Prerequisites

- Ensure that the appropriate field wiring is installed.
 Appropriate wiring is one or more twisted pair or three conductor cables (plenum or non-plenum as required) within the maximum wiring run length for the humidity/temperature controller. The maximum recommended length is 750 feet (229 m).
- Ensure that all wiring complies with National Electric Code (NEC) and local regulations.

Installation

Always mount the sensor vertically.

Locate the sensor:

- According to design specifications and local regulations.
- Where the air circulates around it freely (not in recessed areas or behind doors).
- Allowing a minimum of 4 inches (10 cm) of free space above and below for proper airflow and access.
- Away from drafts caused by doors, windows, outside walls, air registers, pipes, return air plenums, etc.
- Away from heat sources, such as strong lights, fireplaces, direct sunlight, etc.
- On an inside wall (preferably), about 5 feet (1.5 m) above the finished floor.

Installation, Continued

NOTES: Local codes (such as the Americans with Disabilities Act) may require a specific mounting height.

The end of the conduit at the sensor must be sealed to prevent inaccurate measurements due to drafts through the conduit.

Drywall Mounting (No Rough-in), Typical

1. Place a small screwdriver into the top of the sensor and press in the locking tab to remove the cover.

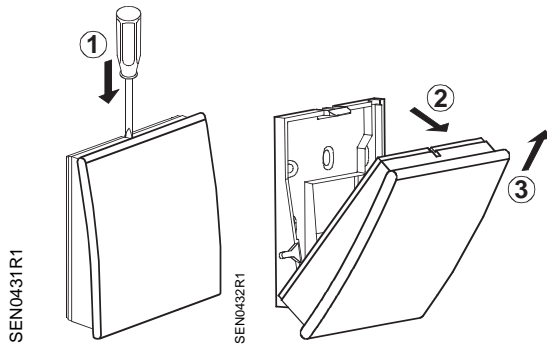

Figure 1.

2. Using the base as a template, mark the hole locations with a pencil.
3. Drill two 1/4-inch diameter holes for plastic wall anchors.
4. Using a mallet, tap in the plastic wall anchors flush with wall.

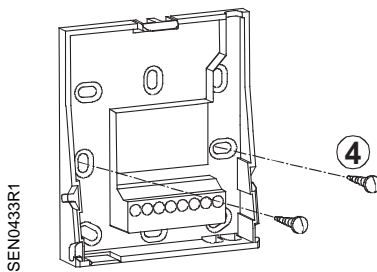

Figure 2.

5. Pull the wiring through the opening in the upper portion of the base.
6. Level the base and fasten it to the wall using two wood screws. The sensor is not position sensitive.
7. Pull the wiring through the base.

8. Position sensor housing over the two mounting lugs located at the top of the base and press down on cover until bottom lugs snap in place.
9. Terminate wires per wiring instructions on the inside of sensor cover.

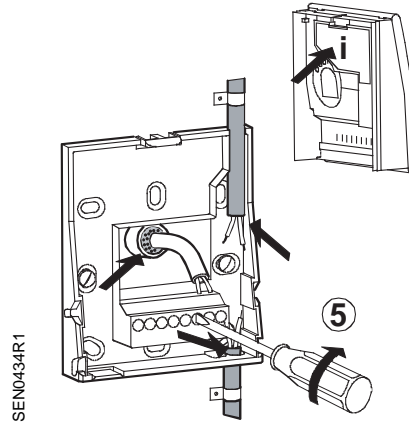

Figure 3.

10. Check that:
 - a. The wires from the humidity sensing membrane are separated from each other and are not in contact with the PCA.
 - b. The humidity sensing membrane has "free space" and is not in contact with the PCA or the temperature sensing element. See Figure 3.
11. Insert the top of the sensor cover into the slots located on the bottom of the sensor and press up until the locking tab snaps into place.

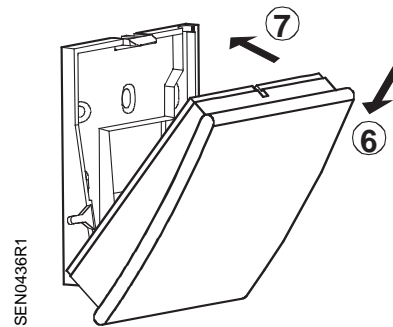

Figure 4.

The installation is now complete.

2 x 4-inch Electrical Wall Box Mounting

An ARG70 wall plate adapter is required to mount a Q-Series CO₂ Room Sensor to a 2 x 4-inch electrical wall box. The ARG70 must be ordered separately.

1. Place a small screwdriver into the top of the sensor and press in the locking tab to remove the cover.
2. Using the two screws provided, fasten wall box adapter to plaster ring, supplied by others.
3. Flex adapter mask and snap in place inside wall box adapter.
4. Fasten sub-base, included with the Q-Series CO₂ Room Sensor, to wall box adapter assembly with the two screws provided.
5. Pull wires through plaster ring.
6. Follow *Drywall Mounting* Steps 6 through 11.

The installation is now complete.

Installing Temperature Sensing Elements (QPA2080 and QPA2080D Only)

QPA2080 and QPA2080D are shipped with four sensing elements: NTC 10K Ohm, Platinum 1000, Nickel 1000 and Platinum 100 (packaged separately).

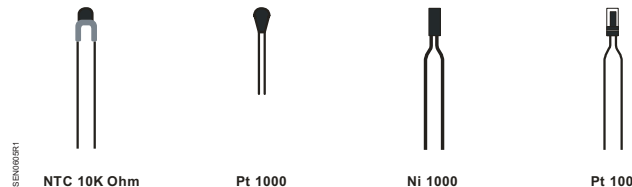

Figure 5. Sensing Element Selections.

To install the sensing element of your choice:

1. Insert the element as shown in Figure 6.
2. Using a small, flat-blade screwdriver, tighten the sensor's two mounting screws.

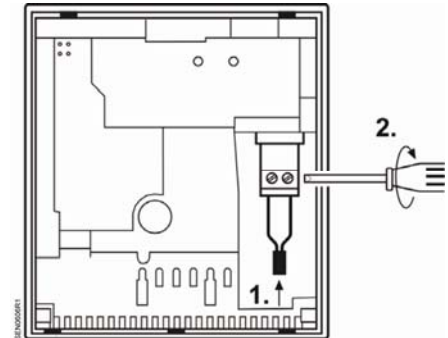

Figure 6. Installing the Sensing Element.

Commissioning

- The sensor's functions can be checked 30 minutes after applying power.
- Checking the CO₂ function:
In well-ventilated rooms, the sensor shows the CO₂ concentration of the outside air. Typically, this is 360 ppm (depending on the sensor's measuring accuracy). Also, a basic functional check can be made by exhaling on the sensor. Note that the sensor's rate of response has been purposely delayed (time constant $t_{90} = 5$ minutes).
- Checking the VOC function:
Touch the sensor with a cotton ball doused in alcohol.
- Ventilation should start when the preset switching level of the connected controller is reached.
- After applying power to sensors with display, Init will appear for about six seconds.
- See *QPA Series Indoor Air Quality Room Sensors Technical Instructions* (CE1N1961) for information on positioning the jumpers on the setting elements.

Wiring Diagrams

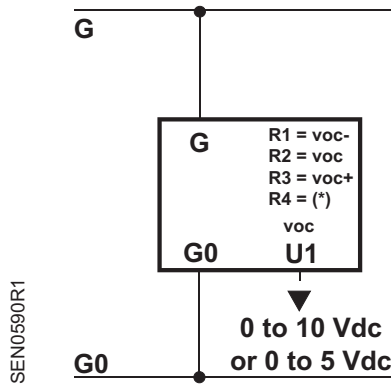

Figure 7. QPA1000.

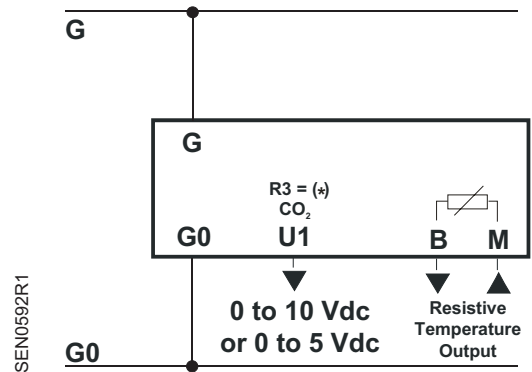

Figure 8. QPA2080, QPA2080D.

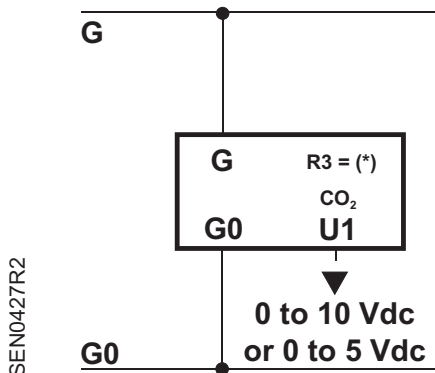

Figure 9. QPA2000 QPA2000N.

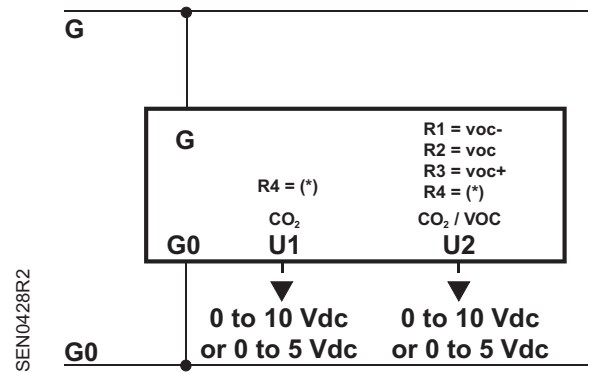

Figure 10. QPA2002, QPA2002D, QPA2002N.

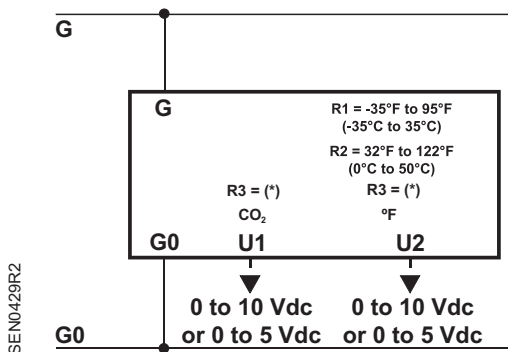

Figure 11. QPA2060, QPA2060D, QPA2060N.

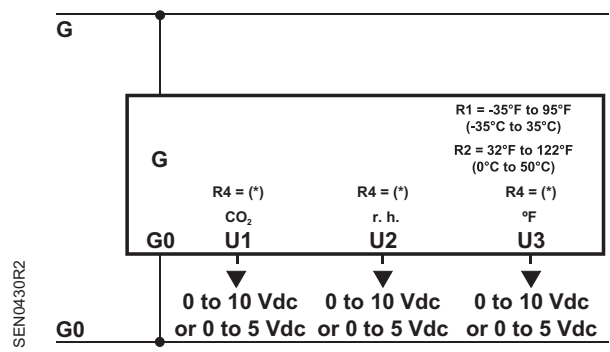

Figure 12. QPA2062, QPA2062D.

G, G0	System potential 24 Vac (SELV)	U3	Signal output 0 to 10 Vdc or 0 to 5 Vdc
G0	System neutral and measuring neutral	R..(*)	Signal output with R... = 0 to 10 Vdc; without R... = 0 to 5 Vdc
U1	Signal output 0 to 10 Vdc or 0 to 5 Vdc	B, M	Passive temperature output (interchangeable)
U2	Signal output 0 to 10 Vdc or 0 to 5 Vdc		

Information in this publication is based on current specifications. The company reserves the right to make changes in specifications and models as design improvements are introduced. Product or company names mentioned herein may be the trademarks of their respective owners. © 2011 Siemens Industry, Inc.