

## LOAD UNIT SERIES LTC200

The ESBE load unit series LTC200 is used to automatically and efficiently load storage tanks and protect solid fuel boilers from too low return temperatures, which otherwise could cause tarring, reduced output and shorter life span of the boiler. The load unit is developed according to the important European Directive 2009/125/EC regarding Eco-design of Energy Related Products and reduces electricity consumption with up to 70%. Patent pending.

### OPERATION

The ESBE series LTC200 is a load unit designed to protect the boiler from return temperatures that are too low. Maintaining a high and stable return temperature enables a higher level of boiler efficiency, reduced tarring and increased life span of the boiler.

The LTC200 is used in heating applications where solid fuel boilers are used to feed storage tanks.

### FUNCTION

The load unit consists of an integrated pump and thermic valve, designed to make both assembly and handling easy. The new pump reduces electricity consumption with up to 70% compared to standard pumps.

To further increase the energy efficiency the pump speed is fully adjustable, enabling the pump speed to be set exactly right for the system and optimizing the loading of the storage tank.

The load unit is protected by an insulation shell and is fitted with easily readable thermometers.

The valve regulates on two ports, which makes it easy to install and does not require any balancing valve in the bypass pipe.

The LTC200 has an integrated auto-circulation function which makes the unit operational even during power failure or pump failure. The circulation function is blocked at delivery, but can easily be activated if required.

An integrated venting function is included in the LTC200. By alternating for 10 minutes, between low and high speed of the pump, any residual air is pushed out of the load unit and can be vented from the system. After the routine is run, the pump switches automatically to a pre-set speed.

The valve contains a thermostat which begins to open connection A when the outgoing mixed water temperature in connection AB exceeds the lower end of the regulating range. Connection B is fully closed when the temperature in connection A exceeds the nominal temperature with 5°C.

### MOUNTING

The pump is equipped with a power supply cable of 0.1 meters, with male connector mounted. Female connector is enclosed.

### MEDIA

Maximum 50% glycol for freezing protection and oxygen absorbing compounds are allowed as additives. As both the viscosity and the thermal conduction are affected when glycol is added to the system water, this fact has to be considered when dimensioning the unit.



Internal thread



### LOAD UNIT LTC200 DESIGNED FOR

- Heating

#### TECHNICAL DATA

Pressure class: \_\_\_\_\_ PN 6  
 Temperature of medium: \_\_\_\_\_ max. 110°C  
 \_\_\_\_\_ min. 0°C  
 Ambient temperature: \_\_\_\_\_ max. 60°C  
 \_\_\_\_\_ min. 0°C  
 Leakrate A - AB: \_\_\_\_\_ max. 0,5% of max. flow ( $Q_{max}$ )  
 Leakrate B - AB: \_\_\_\_\_ max. 3% of max. flow ( $Q_{max}$ )  
 Rangeability  $K_v/K_{vmin}$ : \_\_\_\_\_ 100  
 Supply voltage: \_\_\_\_\_ 230 ± 10% VAC, 50 Hz  
 Power consumption, - LTC261: \_\_\_\_\_ 3 – 45W  
 LTC271: \_\_\_\_\_ 3 – 76W  
 Energy classification: \_\_\_\_\_ A  
 EEI (Energy Efficiency Index) \_\_\_\_\_ <0.23  
 Power supply cable: \_\_\_\_\_ 0.1 m  
 Connections: \_\_\_\_\_ Internal thread (G), ISO 228/1

#### Material

Valve body and cover: \_\_\_\_\_ Nodular iron EN-JS 1050



LVD 2014/35/EU  
 EMC 2014/30/EU  
 RoHS 2011/65/EC  
 PED 2014/68/EU, article 4.3



ErP 2009/125/EU  
 ErP 2015

Pressure Equipment in conformity with PED 2014/68/EU, article 4.3 (sound engineering practice).

#### FLOW PATTERN

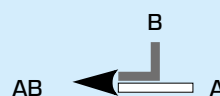

#### WIRING

The pump should be preceded by a multi-pole contact breaker in the fixed installation.

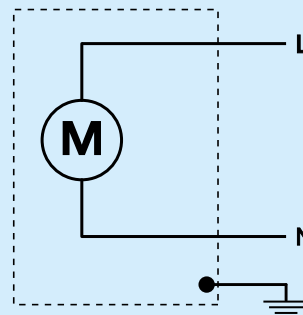

# LOAD UNIT SERIES LTC200

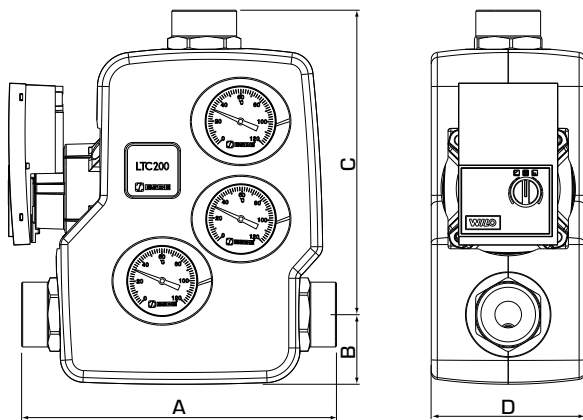

## SERIES LTC261 Internal thread with electronic 6 m pump

Art. No.	Reference	DN	Connection Adapter	Power* [kW] (max. Δt)		Opening temperature	A	B	C	D	Weight [kg]
55004000	LTC261	25	G 1"	95	35	55°C ± 5°C	207	50	209	110	4.4
55004100				80	30	60°C ± 5°C					
55004200				65	25	65°C ± 5°C					
55004300				55	20	70°C ± 5°C					
55004400	LTC261	32	G 1¼"	95	35	55°C ± 5°C	227	50	219	110	4.6
55004500				80	30	60°C ± 5°C					
55004600				65	25	65°C ± 5°C					
55004700				55	20	70°C ± 5°C					
55004800	LTC261	40	G 1½"	95	35	55°C ± 5°C	241	50	226	110	4.6
55004900				80	30	60°C ± 5°C					
55005000				65	25	65°C ± 5°C					
55005100				55	20	70°C ± 5°C					

## SERIES LTC271 Internal thread with electronic 7.5 m pump

Art. No.	Reference	DN	Connection Adapter	Power* [kW] (max. Δt)		Opening temperature	A	B	C	D	Weight [kg]
55007100	LTC271	40	G 1½"	130	40	50°C ± 5°C	241	50	226	110	4.6
55007200				115	35	55°C ± 5°C					
55007300				100	30	60°C ± 5°C					
55007400				80	25	65°C ± 5°C					
55007500				65	20	70°C ± 5°C					
55007600	LTC271	50	G 2"	130	40	50°C ± 5°C	246	50	228	110	6.0
55007700				115	35	55°C ± 5°C					
55007800				100	30	60°C ± 5°C					
55007900				80	25	65°C ± 5°C					
55008000				65	20	70°C ± 5°C					

\* The following recommendations apply only for this product.

For the overall system requirements, restrictions in the possible power output can occur, (available Δp = 15 kPa).

# LOAD UNIT SERIES LTC200

## DIMENSIONING

**Example:** Start with the heat output of the boiler (e.g. 40 kW) and move horizontally to the right in the diagram to the chosen  $\Delta t$  (recommended by boiler supplier), which is the temperature difference between the riser from the boiler and the return to the boiler (e.g.  $85^{\circ}\text{C} - 65^{\circ}\text{C} = 20^{\circ}\text{C}$ ).

Move vertically up to the curves representing load unit performance. Check that the pump curve overcomes the additional pressure drops in system components such as pipes, boiler and storage tank.

### LTC260 – available pressure of the pump

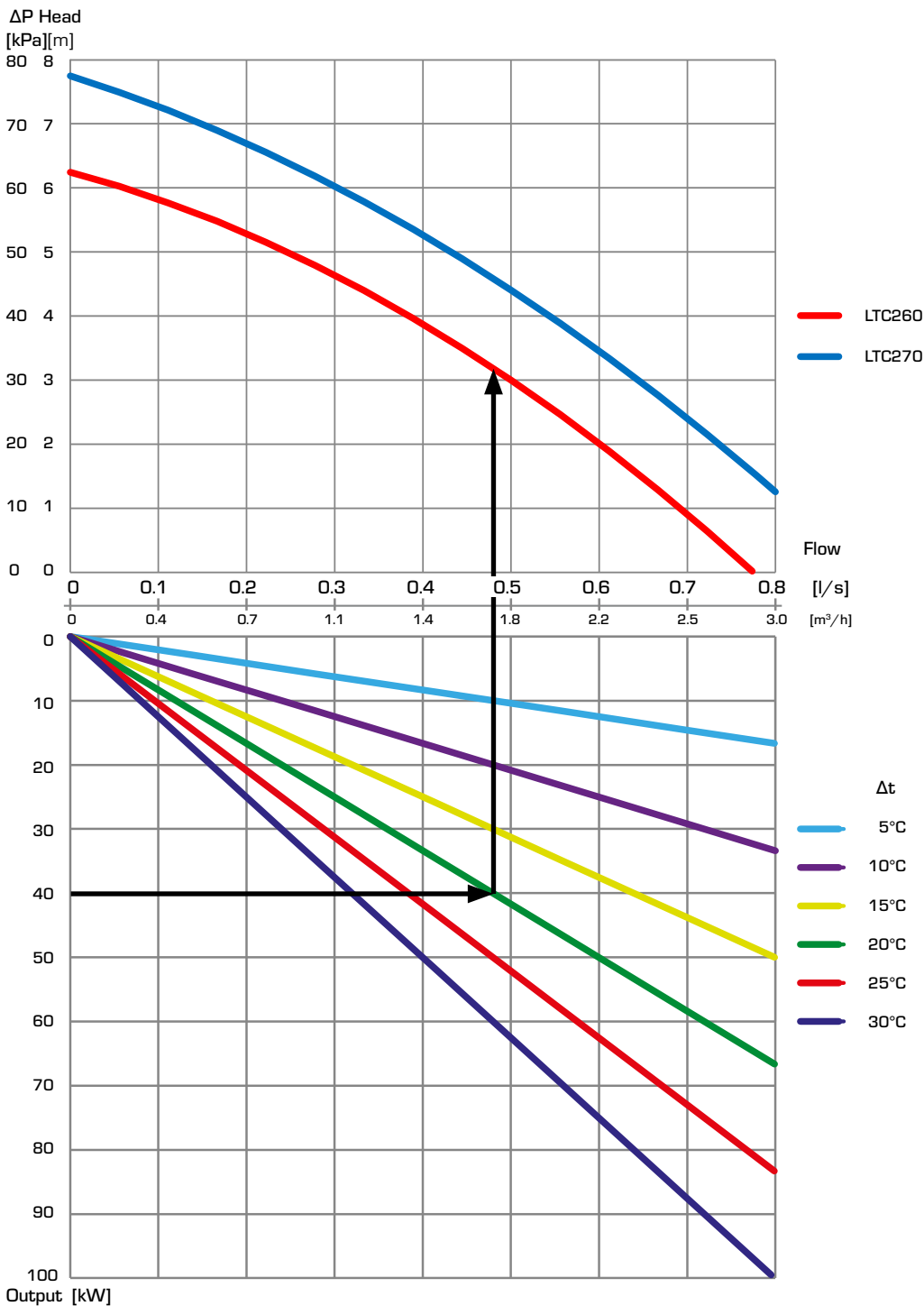

# LOAD UNIT SERIES LTC200

## INSTALLATION EXAMPLE

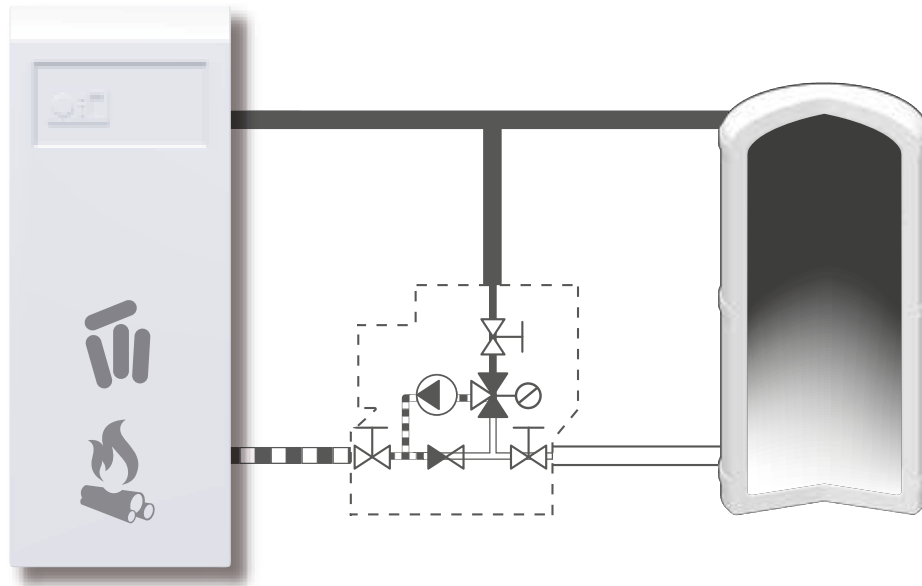

## SERVICE AND MAINTENANCE

The load unit is equipped with shut off ball valves to facilitate future service.

The load unit does not need any maintenance under normal conditions. However thermostats are available and are easy to replace if necessary.

## OPTIONS

- Thermostat 55°C \_\_\_\_\_ Art. No. 5702 02 00
- Thermostat 60°C \_\_\_\_\_ Art. No. 5702 03 00
- Thermostat 65°C \_\_\_\_\_ Art. No. 5702 08 00
- Thermostat 70°C \_\_\_\_\_ Art. No. 5702 04 00